

**"QUARTZ" LLC**

**CURRENT LIMITING FUSES  
PKT AND PKN SERIES**

Technical description and user manual

**UITSG.674351.004 TO**

## 1. Introduction

1.1. This technical description and user manual (UM) are guidelines for the installation, operation, transportation and storage of PKT and PKN fuses of (hereinafter referred to as "fuses") manufactured by "Quartz" LLC according to TU U 3.49-19274160-018-95 and DSTU EN 60282-1:2016.

1.2. The structure of the symbol for fuses is given in Appendix A.

## 2. Purpose

2.1. The fuses are designed for the protection of stationary electrical installations with alternating current at a frequency of 50 and 60 Hz with rated voltage  $U_n$  6, 10 and 35 kV. The PKT series fuses are designed for protection of power transformers, air and cable lines, the PKN series fuses are designed for protection of voltage transformers. Fuses PKN 011-10 and PKN 011-12 can be used to protect voltage transformers at 3 and 6 kV, as well as to protect single-phase power transformers of signaling, centralization and railway blocking devices.

Fuses types PKN 011-10 and PKN 011-12 can also be used to protect power transformers with a capacity of 1,25 kVA with a rated voltage of 6 kV. PKN 011-35 and PKN 011-36 can be used to protect power transformers with a capacity of 4 kVA with a rated voltage of 27,5 kV and transformers with a capacity of 10 kVA with a rated voltage of 35 kV.

2.2. The climatic designs of fuses and the category of fuses location U1, U3, XL1, T3 according to GOST 15150-69.

2.3. Fuses should be used in electrical installations under the following conditions:

- the operating temperature of the ambient air, depending on the climatic version is:
  - categories U1 and U3 from -45 to +40 °C;
  - categories HL1 from -60 to +40 °C;
  - categories T3 from +1 to +45 °C;
- altitude above sea level – no more than 1000 m;
- working position in space - vertical, deviation from the vertical by 15 is allowed;
- The environment should be non-explosive, should not contain conductive dust, corrosive gases and vapors in concentrations that destroy metals and insulation;
- fuses must be protected from sudden shocks and vibrations;
- the quality of the electrical energy of the protected circuit must comply with the requirements of GOST 13109.

2.4. The reliability of fuse operation in an electrical installation depends not only on the accuracy with which it was manufactured, but also on the conditions for their use, the conditions of transportation and storage, and the attention that is paid to them after installation.

The fuses installed on the high-voltage side of the power transformer must be selected according to the selectivity condition with fuses installed on the low-voltage side, taking into account the expected current overloads and the expected switching currents. Additional equipment must be provided capable of switching off overload currents of the transformer capable of melting the fusible element of the fuse, the value of which is less than the minimum breaking current of the fuses.

### 3. Technical data

3.1. Fuse designs and their main technical data are given in Table 1. The resistance of fuse chucks in the cold state is indicated in the passport.

3.2. Overall, mounting and connecting dimensions and weight of the fuses are given in Appendix B.

3.3. In the range of the breaking currents, the PKT fuses belong to class 2 in accordance with DSTU EN 60282-1:2016 and disconnect the currents without damage from the rated minimum breaking current to the rated current.

3.4. The amplitude value of the voltage generated between the fuse terminals when the currents are disconnected does not exceed the following values:

- for fuses at 6 kV - no more than 15 kV;
- for fuses at 10 kV - no more than 25 kV;
- for fuses at 35 kV - no more than 85 kV.

3.5. The electrical strength of insulation of fuses complies with the requirements of GOST 1516.1.

3.6. PKN series fuses allow a long current load current up to 0,5 A.

3.7. The fuse chucks of the climatic design U and CL of the installation category 1 and the climatic version T of the accommodation category 3 are waterproof.

3.8. According to the characteristics, fuses are current limiting.

Table 1

Type of Fuse	Rated Voltage	Maximum operational Voltage	Rated fuse current	Rated breaking current	Minimum breaking current	Power loss	
	kV	kV	A	kA	A	Wt	
1	2	3	4	5	6	7	
PKT 111-6-2-40 U3 PKT 011-6-2-40 U3	6	7,2	2	40	6	5	
PKT 111-6-3,2-40 U3 PKT 011-6-3,2-40 U3			3,2		10	6	
PKT 111-6-5-40 U3 PKT 011-6-5-40 U3			5		15	8	
PKT 111-6-8-40 U3 PKT 011-6-8-40 U3			8		24	13	
PKT 111-6-10-40 U3 PKT 011-6-10-40 U3			10		30	14	
PKT 111-6-16-40 U3 PKT 011-6-16-40 U3			16		160	30	
PKT 111-6-20-40 U3 PKT 011-6-20-40 U3			20		200	35	
PKT 111-6-31,5-20 U3 PKT 011-6-31,5-20 U3			31,5		20	315	58

1	2	3	4	5	6	7
PKT 111-10-2-31,5 U3 PKT 011-10-2-31,5 U3	10	12	2	31,5	12	7
PKT 111-10-3,2-31,5 U3 PKT 011-10-3,2-31,5 U3			3,2		20	9
PKT 111-10-5-31,5 U3 PKT 011-10-5-31,5 U3			5		30	10
PKT 111-10-8-31,5 U3 PKT 011-10-8-31,5 U3	10	12	8	31,5	48	18
PKT 111-10-10-31,5 U3 PKT 011-10-10-31,5 U3	10	12	10	31,5	60	19
PKT 111-10-16-31,5 U3 PKT 011-10-16-31,5 U3			16		160	40
PKT 111-10-20-31,5 U3 PKT 011-10-20-31,5 U3			20		200	45
PKT 111-10-31,5-31,5 U3 PKT 011-10-31,5-31,5 U3			31,5		315	75
PKT 111-35-2-8 U3 PKT 011-35-2-8 U3	35	40,5	2	8	12	25
PKT 111-35-3,2-8 U3 PKT 011-35-3,2-8 U3			3,2		20	30
PKT 111-35-5-8 U3 PKT 011-35-5-8 U3			5		30	38
PKT 111-35-8-8 U3 PKT 011-35-8-8 U3			8		48	57
PKT 111-35-10-3,2 U3 PKT 011-35-10-3,2 U3			10	3,2	60	60
PKT 112-6-31,5-31,5 U3 PKT 012-6-31,5-31,5 U3	6	7,2	31,5	31,5	315	40
PKT 112-6-40-31,5 U3 PKT 012-6-40-31,5 U3			40		400	55
PKT 112-6-50-31,5 U3, U1 PKT 012-6-50-31,5 U3, U1			50		500	70
PKT 112-6-63-31,5 U3 PKT 012-6-63-31,5 U3			63		630	90
PKT 112-6-80-20 U3 PKT 012-6-80-20 U3			80	20	800	120
PKT 112-10-31,5-31,5 U3 PKT 012-10-31,5-31,5 U3	10	12	31,5	31,5	315	50
PKT 112-10-40-31,5 U3 PKT 012-10-40-31,5 U3			40		400	67
PKT 112-10-50-31,5 U3, U1 PKT 012-10-50-31,5 U3, U1			50		500	90
PKT 112-10-63-31,5 U3 PKT 012-10-63-31,5 U3			63		630	120
PKT 112-35-10-8 U3 PKT 012-35-10-8 U3	35	40,5	10	8	60	60
PKT 112-35-16-8 U3 PKT 012-35-16-8 U3			16		100	100
PKT 112-35-20-8 U3 PKT 012-35-20-8 U3			20		120	120

1	2	3	4	5	6	7
PKT 113-6-80-31,5 U3 PKT 013-6-80-31,5 U3	6	7,2	80	31,5	800	110
PKT 113-6-100-31,5 U3 PKT 013-6-100-31,5 U3			100		1000	135
PKT 113-6-125-31,5 U3 PKT 013-6-125-31,5 U3			125		1250	180
PKT 113-6-160-20 U3 PKT 013-6-160-20 U3	6	7,2	160	20	1600	240
PKT 113-10-80-31,5 U3, U1 PKT 013-10-80-31,5 U3, U1	10	12	80	31,5	800	145
PKT 113-10-100-31,5 U3 PKT 013-10-100-31,5 U3			100		1000	180
PKT 113-35-31,5-8 U3 PKT 013-35-31,5-8 U3	35	40,5	31,5	8	190	200
PKT 113-35-40-8 U3 PKT 013-35-40-8 U3			40		240	240
PKT 111-6-2-20 U3 PKT 011-6-2-20 U3	6	7,2	2	20	6	6
PKT 111-6-3,2-20 U3 PKT 011-6-3,2-20 U3			3,2		10	8
PKT 111-6-5-20 U3 PKT 011-6-5-20 U3			5		15	9
PKT 111-6-8-20 U3 PKT 011-6-8-20 U3			8		24	15
PKT 111-6-10-20 U3 PKT 011-6-10-20 U3			10		30	16
PKT 111-10-2-12,5 U3 PKT 011-10-2-12,5 U3	10	12	2	12,5	6	10
PKT 111-10-3,2-12,5 U3 PKT 011-10-3,2-12,5 U3			3,2		10	11
PKT 111-10-5-12,5 U3 PKT 011-10-5-12,5 U3			5		15	14
PKT 111-10-8-12,5 U3 PKT 011-10-8-12,5 U3			8		24	22
PKT 111-10-10-12,5 U3 PKT 011-10-10-12,5 U3			10		30	23
PKT 111-6-2-40 U1 PKT 011-6-2-40 U1	6	7,2	2	40	6	5
PKT 111-6-3,2-40 U1 PKT 011-6-3,2-40 U1			3,2		10	6
PKT 111-6-5-40 U1 PKT 011-6-5-40 U1			5		15	8
PKT 111-6-8-40 U1 PKT 011-6-8-40 U1			8		24	13
PKT 111-6-10-40 U1 PKT 011-6-10-40 U1			10		30	14
PKT 111-6-16-40 U1 PKT 011-6-16-40 U1			16		160	30
PKT 111-6-20-40 U1 PKT 011-6-20-40 U1			20		200	35

1	2	3	4	5	6	7
PKT 111-6-31,5-20 U1 PKT 011-6-31,5-20 U1	6	7,2	31,5	20	315	58
PKT 111-10-2-20 U1 PKT 011-10-2-20 U1	10	12	2		12	6
PKT 111-10-3,2-20 U1 PKT 011-10-3,2-20 U1			3,2		20	9
PKT 111-10-5-20 U1 PKT 011-10-5-20 U1	10	12	5	20	30	10
PKT 111-10-8-20 U1 PKT 011-10-8-20 U1	10	12	8		48	18
PKT 111-10-10-20 U1 PKT 011-10-10-20 U1			10		60	19
PKT 111-10-16-31,5 U1 PKT 011-10-16-31,5 U1			16	160	40	
PKT 111-10-20-31,5 U1 PKT 011-10-20-31,5 U1	10	12	20	31,5	200	45
PKT 111-10-31,5-31,5 U1 PKT 011-10-31,5-31,5 U1			31,5		315	75
PKN 011-10 HL1, U1, U3 PKN 011-35 HL1, U1, U3			10 35		12 40,5	Not standardized
PKT 111-7,2-2-40 T3 PKT 011-7,2-2-40 T3	6	7,2	2	40	6	5
PKT 111-7,2-3,2-40 T3 PKT 011-7,2-3,2-40 T3			3,2		10	6
PKT 111-7,2-5-40 T3 PKT 011-7,2-5-40 T3			5		15	8
PKT 111-7,2-8-40 T3 PKT 011-7,2-8-40 T3			8		24	13
PKT 111-7,2-10-40 T3 PKT 011-7,2-10-40 T3			10		30	14
PKT 111-7,2-16-40 T3 PKT 011-7,2-16-40 T3			16		160	30
PKT 111-7,2-20-40 T3 PKT 011-7,2-20-40 T3			20	200	35	
PKT 111-7,2-31,5-20 T3 PKT 011-7,2-31,5-20 T3			31,5	20	315	58
PKT 111-12-2-31,5 T3 PKT 011-12-2-31,5 T3			10	12	2	31,5
PKT 111-12-3,2-31,5 T3 PKT 011-12-3,2-31,5 T3	3,2	20			9	
PKT 111-12-5-31,5 T3 PKT 011-12-5-31,5 T3	5	30			10	
PKT 111-12-8-31,5 T3 PKT 011-12-8-31,5 T3	8	48			18	
PKT 111-12-10-31,5 T3 PKT 011-12-10-31,5 T3	10	60			19	
PKT 111-12-16-31,5 T3 PKT 011-12-16-31,5 T3	16	160			40	
PKT 111-12-20-31,5 T3 PKT 011-12-20-31,5 T3	20	200			45	

1	2	3	4	5	6	7
PKT 111-36-2-8 T3 PKT 011-36-2-8 T3	35	36	2	8	12	25
PKT 111-36-3,2-8 T3 PKT 011-36-3,2-8 T3			3,2		20	30
PKT 111-36-5-8 T3 PKT 011-36-5-8 T3			5		30	38
PKT 111-36-8-8 T3 PKT 011-36-8-8 T3	35	36	8	8	48	57
PKT 111-36-10-3,2 T3 PKT 011-36-10-3,2 T3			10	3,2	60	60
PKT 112-7,2-31,5-31,5 T3 PKT 012-7,2-31,5-31,5 T3	6	7,2	31,5	31,5	315	40
PKT 112-7,2-40-31,5 T3 PKT 012-7,2-40-31,5 T3			40		400	55
PKT 112-7,2-50-31,5 T3 PKT 012-7,2-50-31,5 T3			50		500	70
PKT 112-12-31,5-31,5 T3 PKT 012-12-31,5-31,5 T3	10	12	31,5	31,5	315	50
PKT 112-12-40-31,5 T3 PKT 012-12-40-31,5 T3			40		400	67
PKT 112-36-10-8 T3 PKT 012-36-10-8 T3	35	36	10	8	60	60
PKT 112-36-16-8 T3 PKT 012-36-16-8 T3			16		100	100
PKT 112-36-20-8 T3 PKT 012-36-20-8 T3			20		120	120
PKN 011-12 T3	10	12	Not standardized			
PKN 011-36 T3	35	36				

#### 4. Package Contents

4.1. The fuses consist of a replaceable fusible element, supporting insulators and contacts, which are supplied as separate components. The designations and list of fuse components are given in Appendix B. The fusible element of fuses PKT 011, PKT 111, PKT 012, PKT 112 and PKN 011 consists of one chuck; fuses PKT 013 and PKT 113 – of two soldered chucks; fuses PKT 014 and PKT 114 - of four chucks.

4.2. A complete set of fuses includes:

- replaceable fusible element;
- two support insulators;
- two contacts;
- a set of fasteners according to the design documentation;
- Passport for a batch of similar fuses, supplied to one address.

**Note.** At the request of the consumer, fuses can be supplied in any packaging set (except for 35 kV supporting insulators).

## 5. The device and operation

The fuse consists of a replaceable fusible element, contacts and supporting insulators, which are connected mechanically and electrically, according to the dimensional-installation drawing, at the installation site. The chuck is installed in the contacts and fixed with a special latch.

The chuck is non-separable, contains a porcelain case with metal caps on the faces. Inside the chuck there is a conductive fusible element, electrically connected to the cap and a fine-grained filler (quartz sand), which provides intensive damping of the electric arc when the current is cut off.

Chucks with an alarm device for triggering have a recessed spring-loaded peg (indicator) at one end, closed by a thin metal membrane. When activated, the peg breaks through the membrane and extends from the chuck to a height of at least 8 mm.

Depending on the climatic design, fuses are equipped with insulators such as IO, IOR or IOS (see Appendix B).

## 6. Packaging

6.1. The components of the fuses are subjected to conservation by the manufacturer, which ensures their safety during the warranty period (two years). Metal parts of chucks and insulators, uncovered by paint, are covered with protective grease, the chuck caps are wrapped with wrapping paper. At the request of the customer, the fuses are not subjected to conservation.

Fuse chucks and supporting insulators are packed in a container and laid with a soft packing material (for example, chips), which protects them from shocks and displacement. Contacts of fuses and fasteners are separately packed in polyethylene bags or wrapped in wrapping paper. Accompanying documentation is packed in plastic bags.

## 7. Transportation and storage

7.1. Fuses in the manufacturer's packaging can be transported by any type of closed transport (vans, wagons, ship holds, etc.). It is allowed to transport fuses in containers without additional packaging, provided that measures are taken to ensure that they are not damaged (by laying chip or sawdust).

7.2. Conditions of transportation and storage with regard to the influence of climatic factors of the external environment - according to the storage conditions group 5 (OZh 4) in accordance with GOST 15150 (temperature from -50 to +50 °C, humidity - not more than 98% at +35 °C).

7.3. Transport conditions in terms of the influence of mechanical factors - for group C according to GOST 23216. During loading and unloading, do not allow sudden shocks and impacts.

7.4. Small batches of fuses (up to 25 pcs.) can be shipped to the packaging of the customer, provided that measures are taken to exclude the possibility of damage during transportation.

7.5. The period of preservation of the component parts of the fuses in the package is two years from the date of shipment under the conditions of transportation and storage. After this period, the fuses must be inspected by the consumer and, if necessary, re-preserved.

## 8. Installation of fuses

8.1. Before installing the fuses, the following operations must be carried out:

- unlock the components by removing the grease with rags moistened with gasoline or a solvent;
- wipe the surface of insulators and chucks with napkins that do not leave a pile;
- with an external inspection, make sure that there are no cracks or chips on porcelain parts of fuses and insulators;
- check the compliance of the operating conditions with the parameters of the fuses indicated in the chuck marking (voltage class, currents, climatic performance);
- check the serviceability of the chucks by the continuity of the electrical circuit.

8.2. Install fuses in accordance with the design documentation and the rules for the setup of electrical installations (SEI).

8.3. Install fuses in the following order:

- install fuse contacts on supporting insulators;



- to install supporting insulators with contacts on structural elements with observance of inter-center distances indicated on the fuse-mounting dimensions, the distance between the phases must comply with the requirements of the setup of electrical installations (SEI);

- adjust the installation of the supporting insulators and contacts so that the longitudinal axes of both contacts of the fuse match and tighten the mounting bolts;

- Attach the supply lines or wires to the fuse terminals, and the external conductors must not transfer significant forces to the insulators;

- install the chucks in the contacts, slowly pressing them until the contact is fully covered by the contacts, selecting the position of the pickup indicator (up or down) from the condition of its best view during the external inspection, and close the latch; in electrical installations of climatic version U1 (external version) fuses should be installed with the indicator downward;

- check the reliability of fastening the chucks in the contacts; when the latch is closed, the chucks should not be turned, and, if necessary, adjust the contacts by clamping or dilating the ends.

When mounting fuses, the fasteners included in the scope of delivery are used.

8.4. The cross section of the external copper conductors connected to the fuse contacts must be at least:

- at a rated current up to 20 A -  $20 \div 30 \text{ mm}^2$ ;
- at a rated current from 31,5 to 63 A -  $40 \div 60 \text{ mm}^2$ ;
- at a rated current from 80 to 200 A -  $120 \div 160 \text{ mm}^2$ .

8.5. If fuses are used at an ambient temperature above  $45 \text{ }^\circ\text{C}$ , but not higher than  $60 \text{ }^\circ\text{C}$ , the current load must be reduced against the rated current of the fuse so that the heating temperature of the contact connections does not exceed  $105 \text{ }^\circ\text{C}$  ( $60 \text{ }^\circ\text{C}$  superheat).

## 9. Security measures

9.1. Install fuses in accordance with the rules for the setup of electrical installations (SEI).

9.2. Operational maintenance of fuses in the process of operation shall be carried out in accordance with the rules for the safe operation of consumers' electrical installations with voltages above 1000V.

9.3. Replacement of chucks must be performed with the equipment disconnected and grounded.

## 10. Instructions for use

10.1. After completing the installation work, it is necessary to check the resistance and the electrical strength of the insulation of the entire electrical installation, including the fuses, in the volume and in accordance with the standards stipulated in the rules for the mounting of electrical installations before switching on the fuses.

10.2. While operating the fuses, periodic preventative maintenance should be carried out in the following volume:

- perform an external inspection to identify mechanical damage or fuses that have tripped;
- wipe the surface of insulation parts;
- check the reliability of the connections and, if necessary, tighten them;
- check the integrity of the fuse chucks;
- check the resistance and electrical strength of insulation of supporting insulators.

Scheduled preventive maintenance work should be carried out at least once a year, in addition to checking the insulation, which must be carried out at the time and according to the standards for the electrical installation as a whole.

10.3. In the event of a fuse operating in one or two phases of a three-phase network, it is recommended to replace the chucks in all three phases, unless there is a firm belief that the breaking current has not passed through the fuse that has not melted.

10.4. In the event of a fall or other severe mechanical impact on the fuse chuck, it shall be ensured that there is no mechanical damage to the porcelain body or a false operation of the indicator, and that the fuse element is in good working order by measuring the electrical resistance of the fuse and comparing it with the passport data.

10.5. It is recommended to repair the burnt fuses at the manufacturer's factory. This requires special technological equipment and special materials.

10.6. Fuses do not contain harmful substances and materials. The utilization of fuses must be carried out in accordance with the procedure provided for by the decisions of the regional organization of sanitary and epidemiological surveillance.

### **11. Warranties**

11.1. The manufacturer guarantees that the quality of the fuses meets the requirements of TU U 3.49-19274160-018-95 if the user observes the conditions of transportation, storage, installation and operation in this operating manual.

11.2. Warranty period - 24 months from the date of commissioning, but not later than 36 months from the date of manufacture. For fuses supplied abroad, the guaranteed service life is 12 months from the date of commissioning, but not later than 24 months from the time of the crossing the State Border of Ukraine.

### Decoding of the conventional designation of fuses PKT and PKN:

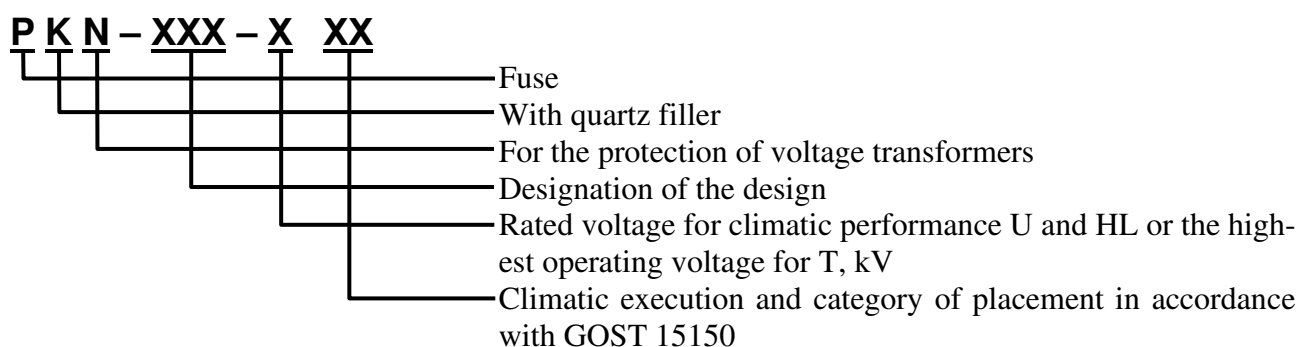
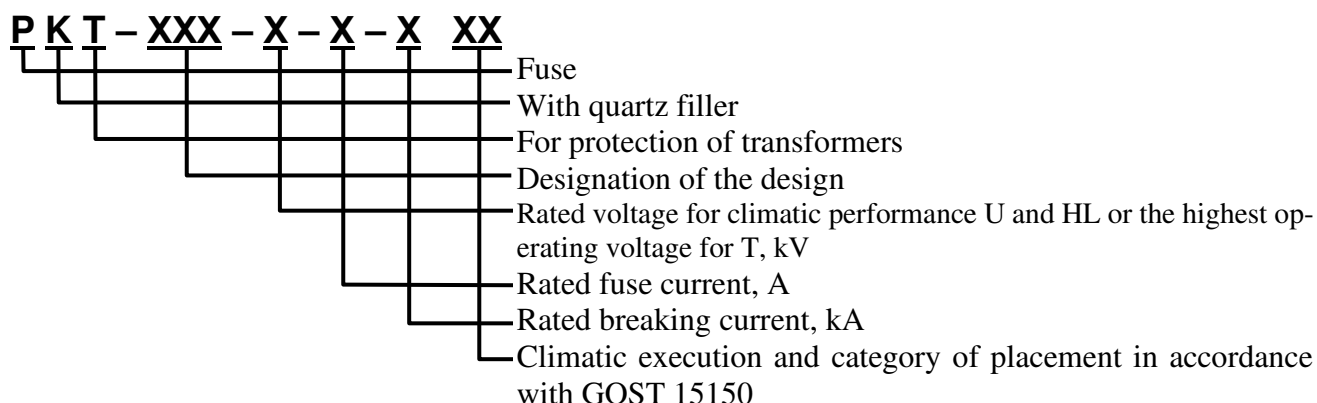

### Designation of the design of the fuse

First digit:

- 0 – without the device for signaling the melting of the fuse;
- 1 – with the device for signaling the melting of a fusible element;

The second and third digits:

- 11 – I gauge (one chuck  $\varnothing 54$  mm);
- 12 – II overall dimensions (one chuck  $\varnothing 70$  mm);
- 13 – III overall dimensions (two chucks  $\varnothing 70$  mm).

## Overall dimensions and weight of fuses

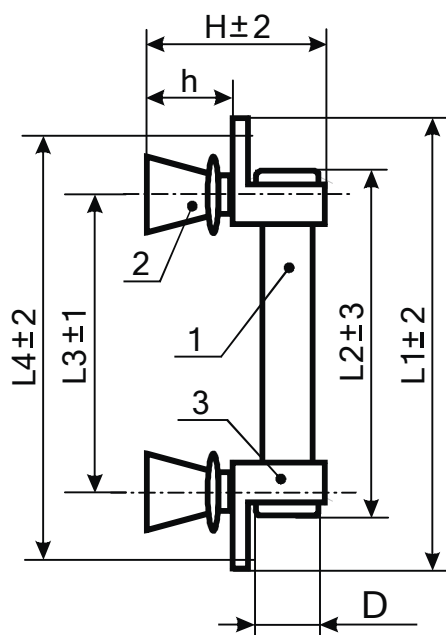

1 – chuck; 2 – insulator; 3 – contact.  
Figure 1.

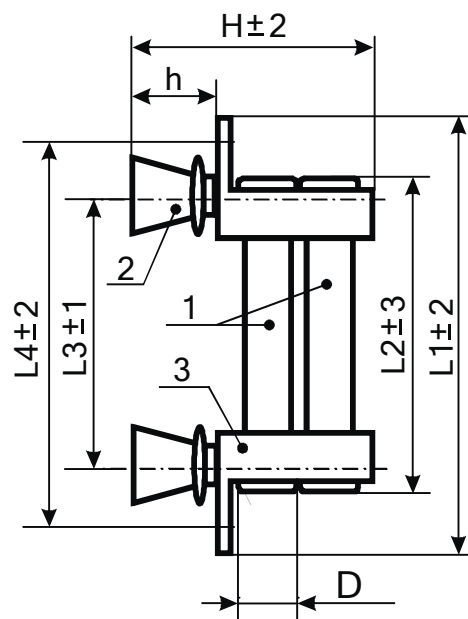

1 – chuck; 2 – insulator; 3 – contact.  
Figure 2.

Table 1

Type of Fuse	Climatic execution	Dimensions, mm							Weight, kg	Figure
		L1	L2	L3	L4	H	h	D		
PKT 111-6 PKT 011-6	U3	404	318	267	380	186	100	54	3,0	1
PKT 112-6 PKT 012-6	U3	454	368	317	430	198	100	70	4,2	1
PKT 113-6 PKT 013-6	U3	454	368	317	430	270	100	70	7,3	2
PKT 111-10 PKT 011-10	U3	504	418	367	480	206	120	54	4,4	1
PKT 112-10 PKT 012-10	U3	554	468	417	530	218	120	70	4,7	1
PKT 113-10 PKT 013-10	U3	554	468	417	530	290	120	70	8,2	2
PKT 111-35 PKT 011-35	U3	734	618	562	710	458	372	54	18,2	1
PKT 112-35 PKT 012-35	U3	784	668	612	760	470	372	70	20,3	1
PKT 013-35 PKT 113-35	U3	784	668	612	760	542	372	70	25	2
PKN 011-10	U3	304	218	167	280	206	120	54	3,8	1
PKN 011-35	U3	734	618	562	710	458	372	54	18,2	1

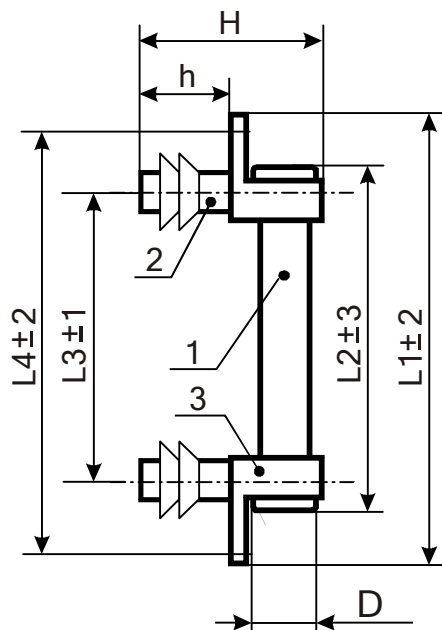

1 – chuck; 2 – insulator; 3 – contact.  
Figure 3.

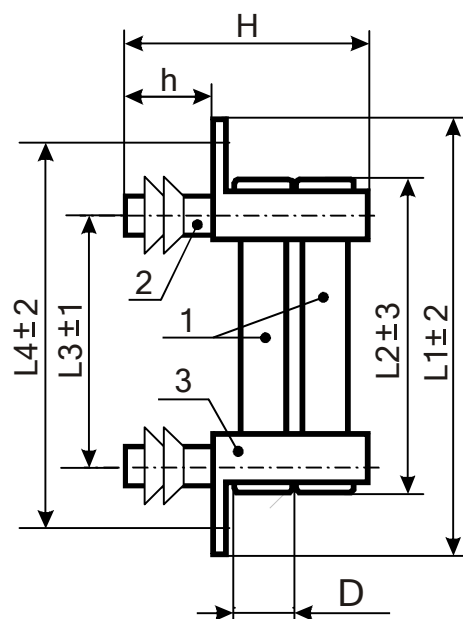

1 – chuck; 2 – insulator; 3 – contact.  
Figure 4.

Table 2

Type of Fuse	Climatic execution	Dimensions, mm							Weight, kg	Figure
		L1	L2	L3	L4	H	h	D		
PKT 111-6 PKT 011-6	U1	404	318	284	380	276	190	54	10,2	3
PKT 112-6 PKT 012-6	U1	454	368	334	430	288	190	70	11,4	3
PKT 111-10 PKT 011-10	U1	504	418	384	480	276	190	54	10,5	3
PKT 112-10 PKT 012-10	U1	554	468	434	530	288	190	70	12	3
PKT 113-10 PKT 013-10	U1	554	468	434	530	360	190	70	15,3	4
PKT 111-35 PKT 011-35	U1	970	618	724	944	526	440	54	35	3
PKT 112-35 PKT 012-35	U1	1020	668	774	994	538	440	70	37	3
PKN 011-10	HL1	504	418	384	480	276	190	54	10,5	3
PKN 011-10	U1	404	318	284	380	276	190	54	10,2	3
PKN 011-35	U1, HL1	970	618	724	944	526	440	54	35	3

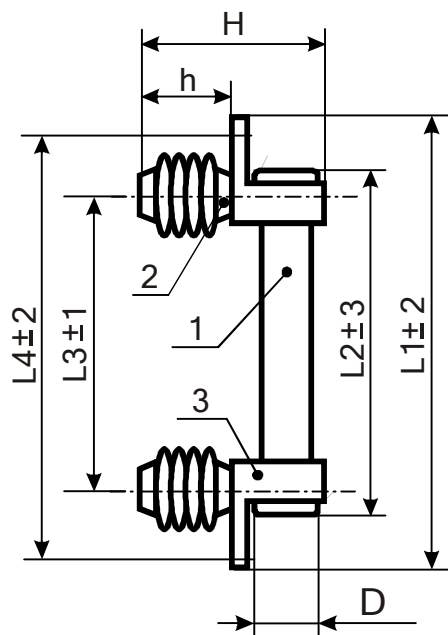

1 – chuck; 2 – insulator; 3 – contact.  
Figure 5.

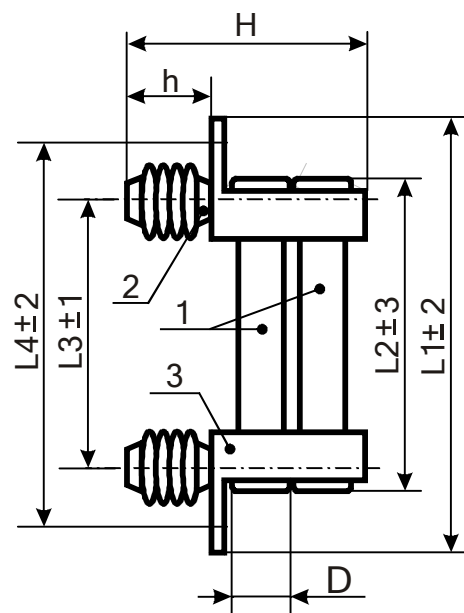

1 – chuck; 2 – insulator; 3 – contact.  
Figure 6.

Table 3

Type of Fuse	Climatic execution	Dimensions, mm							Weight, kg	Figure
		L1	L2	L3	L4	H	h	D		
PKT 111-7,2 PKT 011-7,2	T3	404	318	267	380	186	100	54	3,6	5
PKT 112-7,2 PKT 012-7,2	T3	454	368	317	430	198	100	70	4,8	5
PKT 111-12 PKT 011-12	T3	504	418	367	480	206	120	54	4,9	5
PKT 112-12 PKT 012-12	T3	554	468	417	530	218	120	70	5,5	5
PKT 113-12 PKT 013-12	T3	554	468	417	530	290	120	70	9,7	6
PKT 111-36 PKT 011-36	T3	734	618	562	710	458	372	54	27,8	5
PKT 112-36 PKT 012-36	T3	784	668	612	760	470	372	70	29,9	5
PKN 011-12	T3	404	318	267	380	206	120	54	4,6	5
PKN 011-36	T3	734	618	562	710	458	372	54	27,8	5

## Continuation of the Appendix B

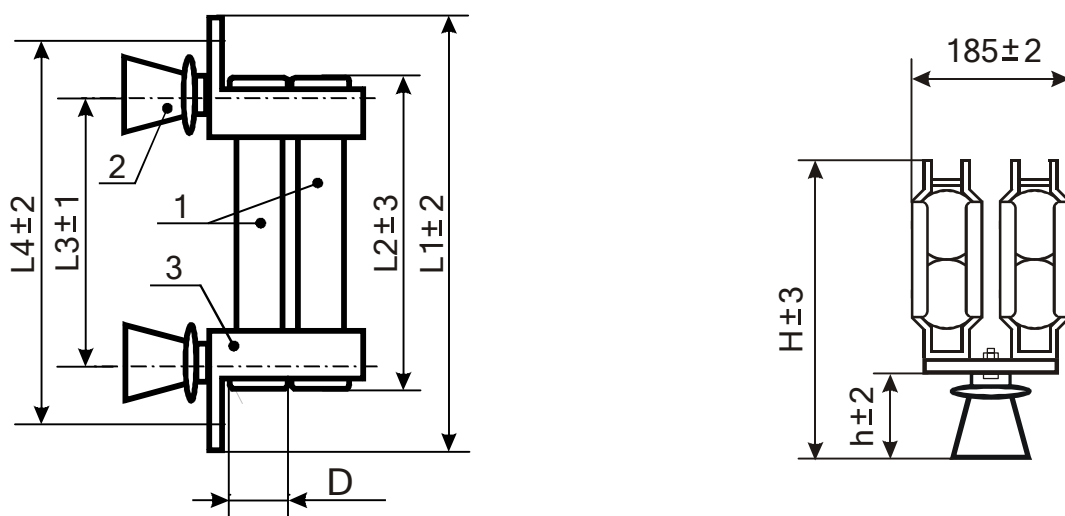

1 – chuck; 2 – insulator; 3 – contact.

Figure 7.

Table 4

Type of Fuse	Climatic execution	Dimensions, mm							Weight, kg	Figure
		L1	L2	L3	L4	H	h	D		
PKT 014-6 PKT 114-6	U3	496	368	352	474	274	100	70	13,1	7
PKT 014-10 PKT 114-10	U3	596	468	452	574	294	120	70	16,3	7

**Notes:**

1. Limit deviations of the mass  $\pm 10\%$ ;
2. The value of overall dimensions and weight of fuses at 35 kV reference, since the types of insulators can vary.

## Composition of fuses

Type of Fuse	Climatic execution	Designation of components		
		Chuck	Contact	Insulator
1	2	3	4	5
PKT 111-6 PKT 011-6	U3	PT 111-6 PT 011-6	K16-10 U3	IO-6-3,75 II U3
PKT 111-10 PKT 011-10	U3	PT 111-10 PT 01110	K16-10 U3	IO-10-3,75 II U3
PKT 111-35 PKT 011-35	U3	PT 111-35 PT 011-35	K16-35 U3	IO-35-3,75 U3
PKT 112-6 PKT 012-6	U3	PT 112-6 PT 012-6	K17-10 U3	IO-6-3,75 II U3
PKT 112-10 PKT 012-10	U3	PT 112-10 PT 012-10	K17-10 U3	IO-10-3,75 II U3
PKT 112-35 PKT 012-35	U3	PT 112-35 PT 012-35	K17-35 U3	IO-35-3,75 U3
PKT 113-6 PKT 013-6	U3	PT 113-6 PT 013-6	K18-10 U3	IO-6-3,75 II U3
PKT 113-10 PKT 013-10	U3	PT 113-10 PT 013-10	K18-10 U3	IO-10-3,75 II U3
PKT 113-35 PKT 013-35	U3	PT 113-35 PT 013-35	K18-35 U3	IO-35-3,75 U3
PKT 111-6 PKT 011-6	U1	PT 111-6 PT 011-6	K16-10 U1	IOC-10-500 HL1
PKT 111-10 PKT 011-10	U1	PT 111-10 PT 011-10	K16-10 U1	IOC-10-500 HL1
PKT 111-35 PKT 011-35	U1	PT 111-35 PT 011-35	K16-35 U1	IOC-35-500 UHL1
PKT 112-6 PKT 012-6	U1	PT 112-6 PT 012-6	K17-10 U1	IOC-10-500 HL1
PKT 112-10 PKT 012-10	U1	PT 112-10 PT 012-10	K17-10 U1	IOC-10-500 HL1
PKT 113-10 PKT 013-10	U1	PT 113-10 PT 013-10	K18-10 U1	IOC-10-500 HL1
PKT 111-7,2 PKT 011-7,2	T3	PT 111-7,2 PT 011-7,2	K16-10 T3	IOR-6-3,75 T2
PKT 111-12 PKT 011-12	T3	PT 111-12 PT 011-12	K16-12 T3	IOR-10-3,75 T2
PKT 111-36 PKT 011-36	T3	PT 111-36 PT 011-36	K16-36 T3	IOR-35-3,75 T2
PKT 112-7,2 PKT 012-7,2	T3	PT 112-7,2 PT 012-7,2	K17-12 T3	IOR-6-3,75 T2
PKT 112-12 PKT 012-12	T3	PT 112-12 PT 012-12	K17-12 T3	IOR-10-3,75 T2
PKT 112-36 PKT 012-36	T3	PT 112-36 PT 012-36	K17-36 T3	IOR-35-3,75 T2
PKT 113-12 PKT 013-12	T3	PT 113-12 PT 013-12	K18-12 T3	IOR-10-3,75 T3



1	2	3	4	5
PKT 114-6	U3	PT 113-6 PT 013-6	K19-10	IO-6-3,75 II U3
PKT 014-6	U3	PT 013-6 PT 013-6	K19-10	IO-6-3,75 II U3
PKT 114-10	U3	PT 113-10 PT 013-10	K19-10	IO-10-3,75 II U3
PKT 014-10	U3	PT 013-10 PT 013-10	K19-10	IO-10-3,75 II U3
PKN 011-10	U3	ΠH 011-10	K16-10 U3	IO-10-3,75 II T3
PKN 011-10	U1	ΠH 011-10	K16-10 U1	IOC-10-500 UHL1
PKN 011-10	HL1	ΠH 011-10	K16-10 HL1	IOC-10-500 UHL1
PKN 011-12	T3	ΠH 011-12	K16-12 T3	IOR-10-3,75 T2
PKN 011-35	U3	ΠH 011-35	K16-35 U3	IO-35-3,75 II U3
PKN 011-35	U1	ΠH 011-35	K16-35 U1	IOC-35-500 UHL1
PKN 011-35	HL1	ΠH 011-35	K16-35 HL1	IOC-35-500 UHL1
PKN 011-36	T3	ΠH 011-36	K16-36 T3	IOR-35-3,75 T2

**Note.** Support insulators of 35 kV are supplied by separate agreement with the manufacturer.