

Ceramic supporting insulators IO and IOR series

Manual UITSG 686112.001 RE

1. General Information

This operating manual applies to ceramic insulators, IO and IOR series (hereinafter "insulators"), manufactured according to technical specifications TU U 31.6-19274160-007:2011, GOST 9984-85 and GOST 19797-85.

The structure of the conventional designation for insulators:

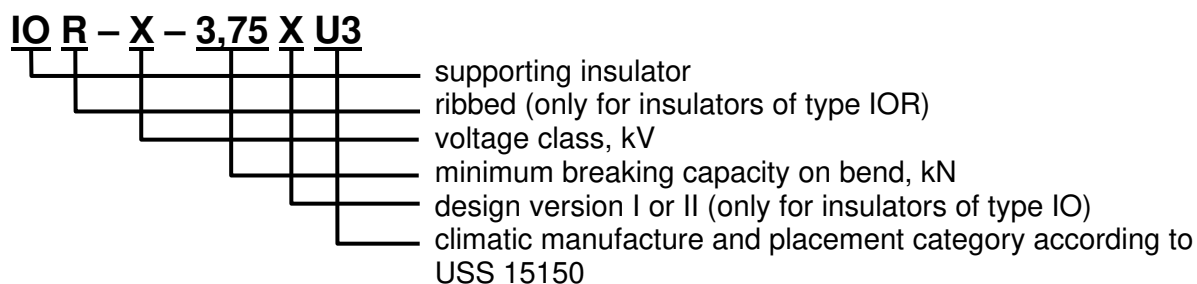

The insulators are designed for insulation and fixing of current-carrying parts in electric devices and switchgears with voltages of 6 and 10 kV of alternating current with a frequency of 50-60 Hz.

The insulators are designed to work in an atmosphere of type I or II according to GOST 15150-69. The climatic manufacture and placement category in accordance with GOST 15150-69 is:

- U3 - for insulators of type IO;
- UHL, T2 - for insulators of type IOR.

The types and main parameters of insulators are given in Table 1.

Table 1

Types of insulators	Rated Voltage, kV	Maximum Allowable Voltage, kV	Minimum Breaking Capacity on bend, kN
IO-6-3,75 I U3	6	7,2	3,75
IO-6-3,75 II U3	6	7,2	3,75
IO-10-3,75 I U3	10	12	3,75
IO-10-3,75 II U3	10	12	3,75
IOR-6-3,75 UHL, T2	6	7,2	3,75
IOR-10-3,75 UHL, T2	10	12	3,75

2. Characteristics of insulators

- 2.1. Test voltage of lightning impulses in accordance with GOST 1516.1.
- 2.2. Test voltage of the industrial frequency in accordance with GOST 1516.1.
- 2.3. Resistance to thermal shock – 70 °C.
- 2.4. Weight of insulators, no more than:
 - IO-6 – 1,1 kg;
 - IOR-6 – 1,1 kg;
 - IO-10 – 1,45 kg;
 - IOR-10 – 1,6 kg.

2.5. Permissible mechanical influencing factors of the environment - according to group M25 of GOST 17516.1.

3. Design

3.1. The overall and installation dimensions of the insulators are given in the Appendix in Fig.1.

3.2. The cases of insulators are made of special high-strength ceramic mass. Metal fittings are mounted in the upper and lower ends of the insulators to fix the insulators to the base and live parts. The outer side of the insulators is covered with glaze. A marking is made on each insulator by method of stamping, which contains the following info:

- type of insulator;
- the trademark of the manufacturer;
- the year of manufacture (last two digits).

4. Content

The set includes:

- the quantity of insulators according to the order;
- a passport in 1 copy for a group of insulators of the same type up to 200 pcs., supplied to one address;
- a manual in 1 copy per group of insulators up to 200 pieces, supplied to one address.

5. Packaging

The insulators are laid in wooden or latticed boxes in accordance with GOST 2991 and separated from each other by a soft cushioning material to protect them from moving and collision. The weight of the boxes with packed insulators is no more than 20 kg.

When shipping of up to 100 pcs of insulators to one address it is allowed to pack the insulators in cardboard in accordance with GOST 12303 with gaskets made of soft material. The weight of one box with packed insulators should be no more than 16 kg.

Handling signs are applied on the side surface of the transport container: "Caution, fragile" and "Top, do not tilt over".

It is allowed to handle insulators to the container of the customer, provided that they take measures to exclude damage to the insulators during their transportation and storage under the responsibility of the customer.

6. Transportation and storage

6.1. The transportation of insulators is allowed to be carried out by all means of transport in covered vehicles with the rules of transportation applied to each mode of transport.

It is allowed to transport insulators without packaging in open cars with protection against precipitation with the help of waterproof material. In this case, the insulators must be laid with damping material and separated from each other by wooden gaskets. The number of layers in height must be no more than 10.

6.2. Transportation conditions in terms of the impact of mechanical factors are "rigid" (g) in accordance with GOST 23216. At the same time, it is not allowed to turn, tilt or drop the packaging containers with insulators or to impact the insulators themselves.

6.3. Climatic conditions for storage of insulators - canopies and premises in macroclimate regions with a temperate and cold climate.

7. Instructions for use

7.1. In addition to this manual, when installing and operating the insulators, it is necessary to comply with the requirements of the current "Rules for the setup of electrical installations", "Safety rules for the operation of electrical installations of consumers" and "Rules for the operation of electrical installations of consumers."

7.2. Climatic operating conditions:

- altitude above sea level – no more than 1000 m;
- the atmosphere is conditionally clean or industrial, type I and II according to GOST 15150;
- placement of insulators of the IO type – in closed rooms, insulators of the IOR type - under a canopy, respectively, categories 3 and 2 in accordance with GOST 15150;
- maximum operating air temperatures:
for insulators of type IO: from +45 °C to -50 °C,
for insulators of type IOR: from +45 °C to -70 °C.

7.3. The permissible mechanical influencing factors of the external environment should not exceed the following values:

- sinusoidal vibration in the range 0,5-100 Hz with a maximum acceleration amplitude of 10 (1) $\text{m} \cdot \text{s}^{-2}$ (g);
- peak impact accelerations - no more than 30 (3) $\text{m} \cdot \text{s}^{-2}$ (g) with a duration of 2-20 ms.

7.4. Tightening of bolts during installation is recommended to be carried out by torque and indicator keys (for example, DK-25). The values of torque at thread diameters: for M8 - $22 \pm 1,5 \text{ N} \cdot \text{m}$, for M10 - $30 \pm 1,5 \text{ N} \cdot \text{m}$, for M12 - $40 \pm 2,0 \text{ N} \cdot \text{m}$.

7.5. After the installation of the insulators in the electrical installation, it is necessary to clean the insulators of dirt and residue.

7.6. Preventive inspections and tests of insulators are carried out in the volume and in terms provided for the entire electrical installation in which the insulators are used.

7.7. Damaged insulators are not subject to repair.

8. Manufacturer's warranty

The manufacturer guarantees that the insulators comply with the characteristics specified in this manual and in the technical conditions for insulators, provided that the consumer observes the conditions of transportation, storage, installation and operation specified in this manual.

Warranty term - 4 years from the date of manufacture.

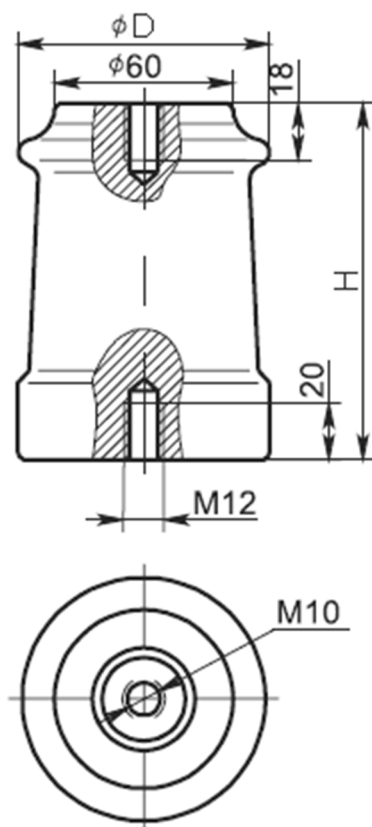

Insulator IO

Type of Insulator	Height H, mm	Diameter D, mm
IO-6-3,75 I U3	100±2	77
IO-10-3,75 I U3	120±2	82

Fig. 1. Overall and installation dimensions of insulators IO-6-3,75 I U3, IO-10-3,75 I U3.

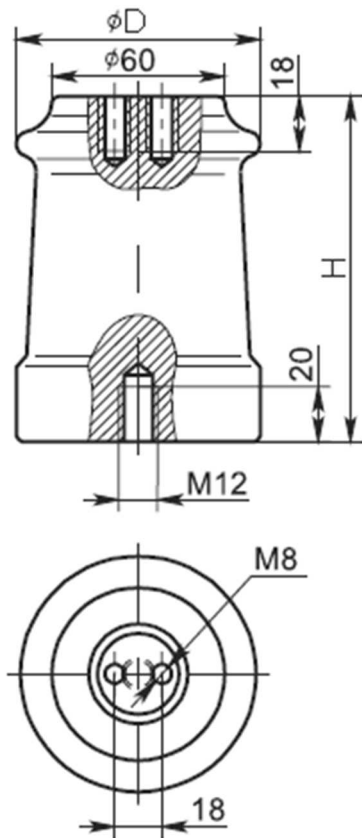

Insulator IO

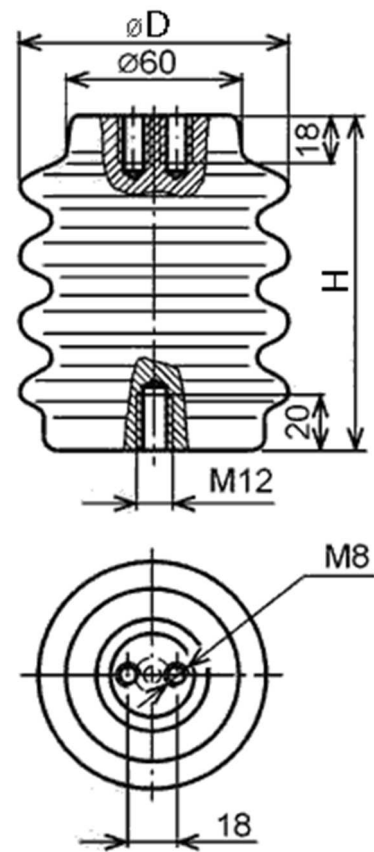

Insulator IOR

Type of Insulator	Height H, mm	Diameter D, mm
IO-6-3,75 II U3	100±2	77
IO-10-3,75 II U3	120±2	82
IOR-6-3,75 UHL, T2	100±2	84
IOR-10-3,75 UHL, T2	120±2	96

Fig. 2. Overall and installation dimensions of insulators IO-6-3,75 II U3, IO-10-3,75 II U3, IOR-6-3,75 UHL, T2, IOR-10-3,75 UHL, T2.